

# Robot RA605 Series

A compact 6-axis jointed robot for complex assembly and processing tasks.  
Applications from transport of mechanical parts to assembly of electrical parts.  
Multiple installation method: Floor, ceiling, and wall.

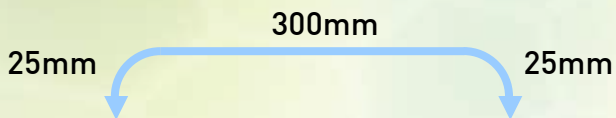

Cycle time is based on back-and-forth movement over a vertical distance of 25 mm and horizontal distance of 300 mm when the load is 1kg.

## Specification

Model	unit	RA605-710
Degrees of freedom		6
Maximum load capacity	kg	6
Maximum reach radius	mm	710
Operating Range (MaximumSpeed)	J1	±170 (360)
	J2	+130~-90 (288)
	J3	+70~-190 (420)
	J4	±190 (450)
	J5	±120 (450)
	J6	±360 (720)
Cycle time*1	sec	0.5
Position repeatability	mm	±0.02
Allowable load moment at wrist	J4	8.5
	J5	8.5
	J6	5.6
Allowable load inertia at wrist	J4	0.3
	J5	0.3
	J6	0.1
Tool wiring		Hand: 4 output point/4 input point
Tool pneumatic pipes		Secondary:φ4×6
Machine cable	m	3 (connector on both end)
Connected controller		XRC6
Mass	kg	40 (Without controller)

# External Dimensions / Operating Range

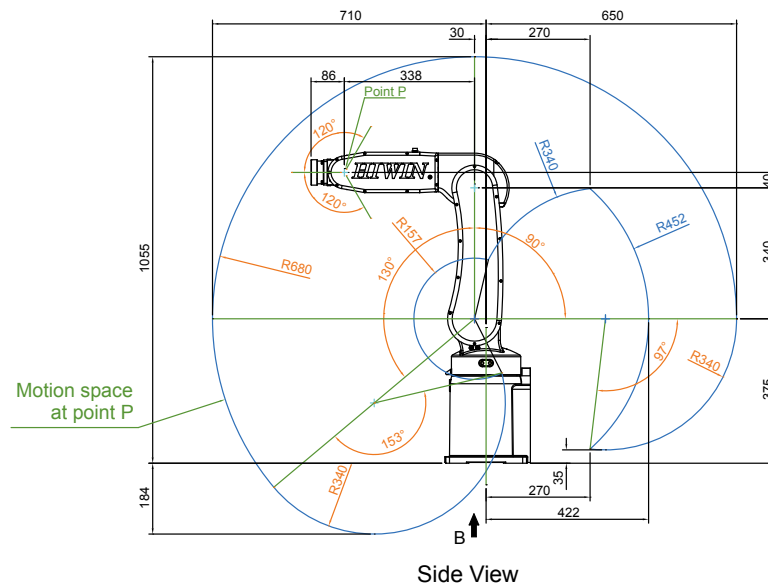
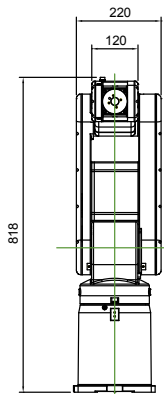
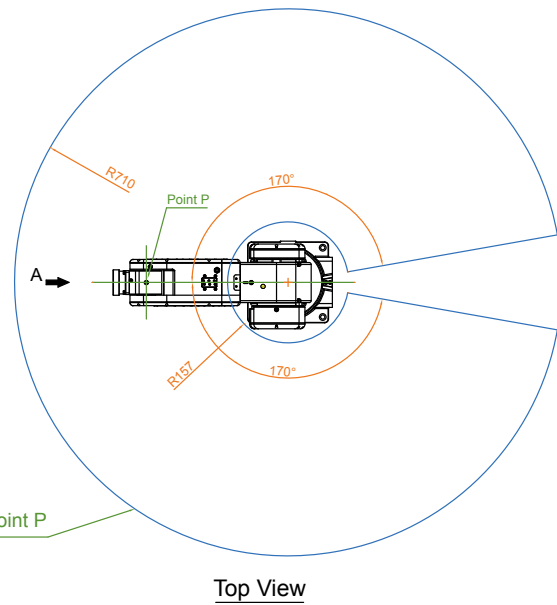
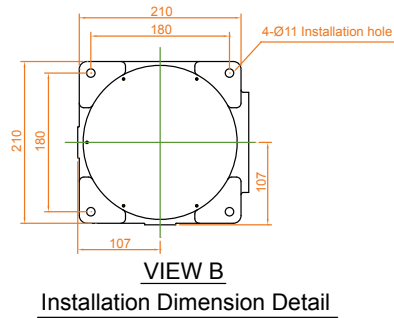
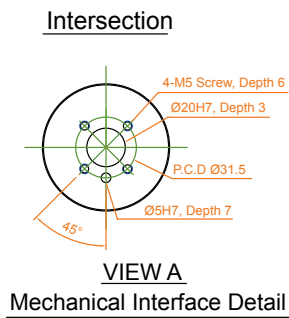

**HIWIN®**  
Motion Control and System Technology



**HIWIN TECHNOLOGIES CORP.**  
No. 7, Jingke Road,  
Taichung Precision Machinery Park,  
Taichung 40852, TAIWAN  
Tel: +886-4-23594510  
Fax: +886-4-23594420  
www.hiwin.com.tw  
business@hiwin.com.tw

## Subsidiaries & RD Centers

**HIWIN GmbH**  
OFFENBURG, GERMANY  
www.hiwin.de  
www.hiwin.eu  
info@hiwin.de

**HIWIN JAPAN**  
KOBE · TOKYO · NAGOYA · KUMAMOTO, JAPAN  
www.hiwin.co.jp  
info@hiwin.co.jp

**HIWIN USA**  
CHICAGO · SILICON VALLEY, U.S.A.  
www.hiwin.com  
info@hiwin.com

**HIWIN s.r.o.**  
BRNO, CZECH REPUBLIC  
www.hiwin.cz  
info@hiwin.cz

**HIWIN SCHWEIZ**  
JONA, SWITZERLAND  
www.hiwin.ch  
info@hiwin.ch

**HIWIN FRANCE**  
L'AIGLE Cedex, FRANCE  
www.hiwin.fr  
info@hiwin.fr

**HIWIN Srl**  
Rho (MI), ITALY  
www.hiwin.it  
info@hiwin.it

**Mega-Fabs Motion System, Ltd.**  
YOKNEAM, ISRAEL  
www.mega-fabs.com  
info@mega-fabs.com